

Electro hydraulic thrusters
THE ORIGINAL. BE SAFE.

ELDRO®

DC series Eg

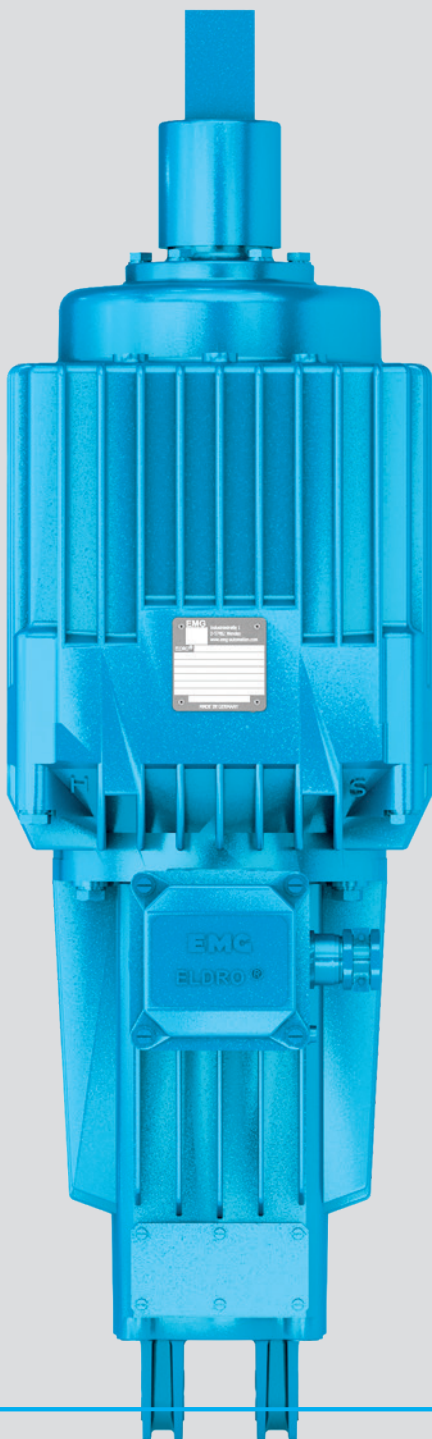

EMG ELDRO® electro hydraulic thrusters

Direct current series Eg

Areas of application

EMG ELDRO® DC thrusters are used in systems with an existing direct current power supply.

The EMG ELDRO® DC series Eg is used to open brakes in the event of a voltage breakdown of the three-phase supply. In this case, these thrusters are installed in the brake as an additional brake thruster and can then be supplied with a direct current voltage, for example, from a battery. This enables loads, for example in lifting units, to be lowered and set down safely.

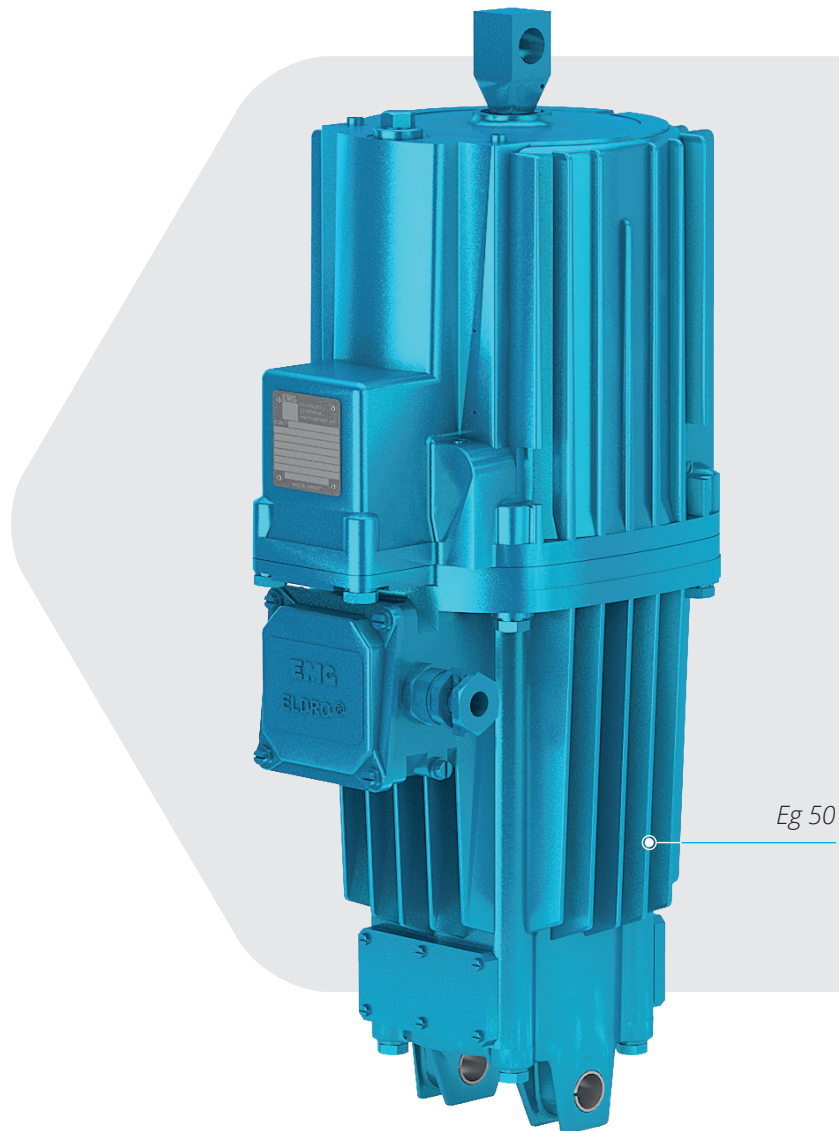

Technical values

Type	Lifting force [N]	Stroke path [mm]**	Power consumption [W]	Current consumption [A] at 220 V DC	Switching frequency with S3 operation [c/h]	Weight [kg]
Eg 50/...	500	60 – 120	350	1.60	600 – 1,000*	27 – 31*
Eg 80/...	800	60 – 120	330	1.50	600 – 1,000*	27 – 31*
Eg 121/...	1,250	60 – 120	330	1.50	500 – 1,000*	43 – 44*
Eg 201/...	2,000	60 – 120	430	2.00	500 – 1,000*	43 – 44*
Eg 301/...	3,000	60 – 120	470	2.20	400 – 800*	43 – 44*

* depending on stroke path ** further on request

Stroke work (N cm) = Lifting force x stroke path

Eg 50 to Eg 80

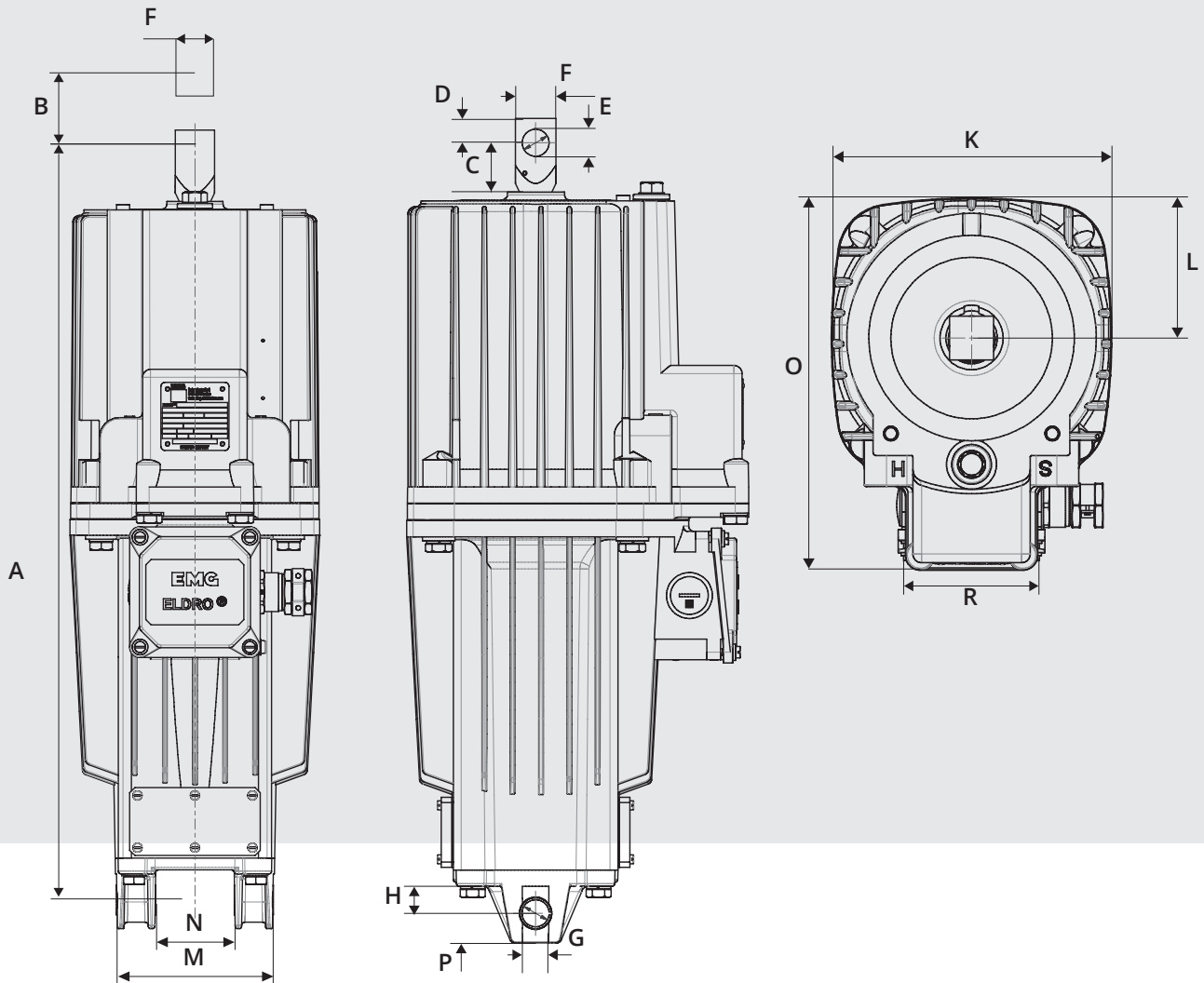

Type	A	B	C	D	E	F	G	H	K	L	M	N	O	P	R
Short stroke thrusters															
Eg 50/...	570	60	36	18	20	30	20	23	195	97	120	60	254	22	90
Eg 80/...	570	60	36	18	20	30	20	23	195	97	120	60	254	22	90
Long stroke thrusters															
Eg 50/...	650	120	36	18	20	30	20	23	195	97	120	60	254	22	90
Eg 80/...	650	120	36	18	20	30	20	23	195	97	120	60	254	22	90

All dimensions in mm | B = stroke path (variable)

EMG ELDRO® electro hydraulic thrusters
Eg 121 to Eg 301

Eg 121

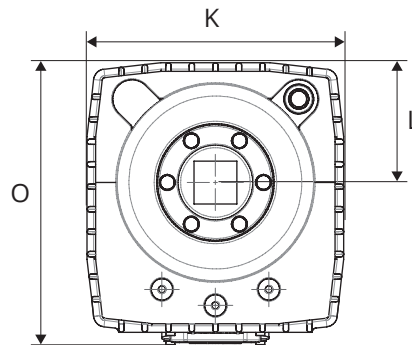
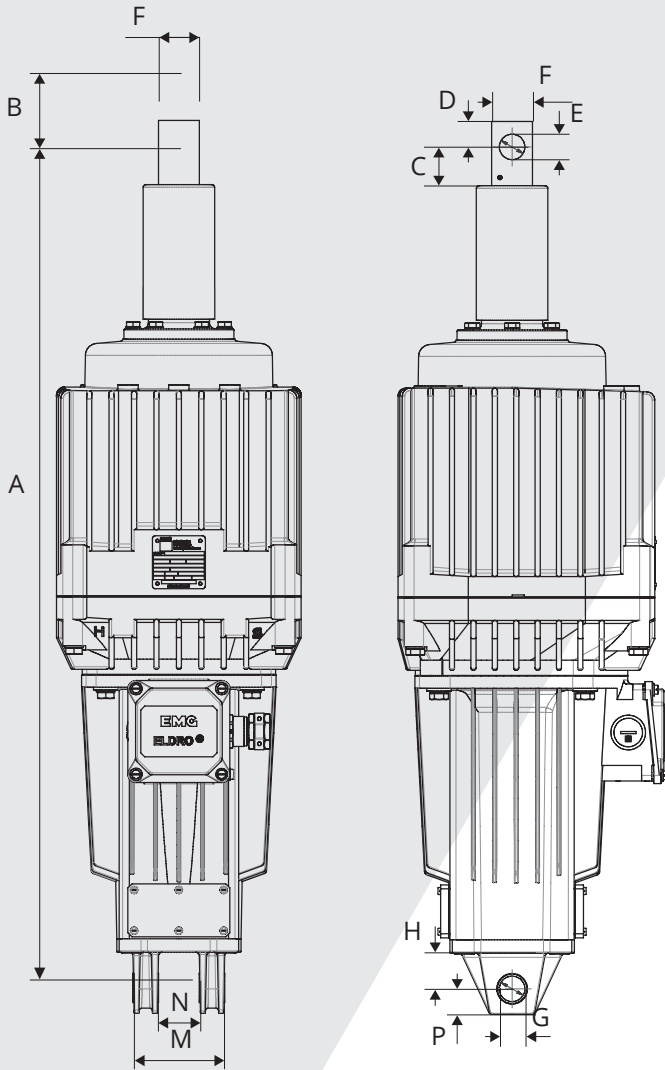

Type	A	B	C	D	E	F	G	H	K	L	M	N	O	P	R	W
Short stroke thrusters																
Eg 121/...	765	60	38	25	25	40	25	35	240	112	90	40	260	25	15	100
Eg 201/...	765	60	38	25	25	40	25	35	240	112	90	40	260	25	15	100
Eg 301/...	765	60	38	25	25	40	25	35	240	112	90	40	260	25	15	100
Long stroke thrusters																
Eg 121/...	825	120	38	25	25	40	25	35	240	112	90	40	260	25	15	100
Eg 201/...	825	120	38	25	25	40	25	35	240	112	90	40	260	25	15	100
Eg 301/...	825	120	38	25	25	40	25	35	240	112	90	40	260	25	15	100

All dimensions in mm | B = stroke path (variable)

EMG ELDRO® electro hydraulic thrusters

Electrical version

Motor

- » DC shunt motor
- » Design according DIN VDE 0530
- » For power data see "Technical values"
- » Standard insulation per insulation class F

Voltages and frequencies

- » Nominal load to form factor 1.05
- » Standard: 220 V DC
- » Special windings 24 V - 500 V DC on request

Cable inlet

- » Threaded cable gland M 25 x 1.5 for cable cross-sections to 4 x 2.5 mm² (Ø 17 - 19 mm)

Operating modes

- » Continuous operation S1 and intermittent duty S3 - 60 % duty cycle standard
- » With ambient temperatures > 35 °C deviating technical values (available on request)

Terminal box

- » Terminal board 6-pole
- » Supply line connection M4
- » Internal protective conductor connection: M4
- » External protective conductor connection: M6

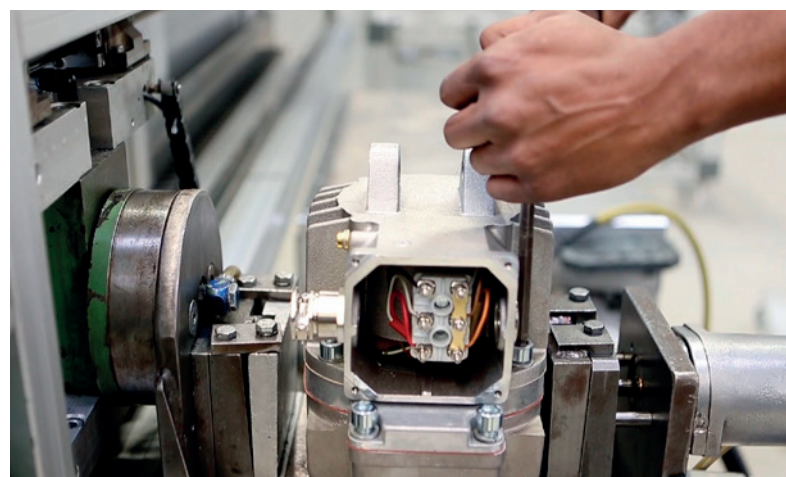



EMG ELORO® electro hydraulic thrusters

Mechanical version

Installation variants

- » The base fastening can be mounted offset through 90° for versions without limit switch
- » The pressure strap at the top rotates in all types
- » In case of versions with a limit switch, minor modifications are required in order to rotate the pressure strap or fasten the base as required

Enclosure

- » Standard IP 65, in special version up to IP 68

Operating fluid

- » Mineral hydraulic oil or silicone oil depending on the operating conditions, e.g. ambient temperature, factory-filled

Paint application per DIN EN ISO 12944

- » Standard for corrosion load C1, layer thickness 70 µm
- » Special paint up to corrosion load C5-M, coating thickness to 280 µm
- » Standard colour RAL 7022 (umbra grey)

Protective measures

- » Redundant dust protection seal
- » Redundant seal with the hydraulic chamber
- » Piston rod chromium plated to dimension
- » With Eg 121, Eg 201 and Eg 301 additional piston rod protective tube against external mechanical influences

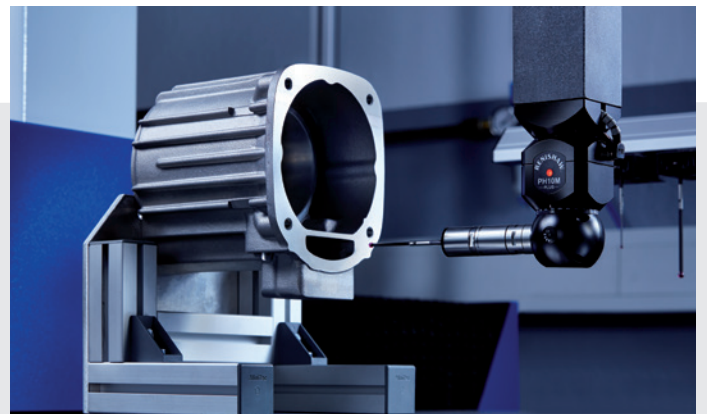

EMG ELDRO® electro hydraulic thrusters

Electrical & mechanical auxiliary equipment

Lifting and/or lowering valve (H, S, HS)

- » The lifting and lowering times can be steplessly extended with an integrated lifting and/or lowering valve. The adjustable minimum values attain 10 to 20-times the normal values
- » Integrated valves in "open position" result in an extension of the lifting and lowering times with short stroke thrusters of up to approx. 0.1 to 0.2 seconds, and with long stroke thrusters of up to approx. 0.2 to 0.4 seconds
- » The desired lifting or lowering time is set externally on the device

Limit switch

- » For the electrical display of the ventilation and braking positions, mechanical or inductive limit switches can be installed on all ELDRO® thrusters
- » Detailed information available in the data sheet of the limit switches

Increased corrosion protection

- » Increased corrosion protection is necessary with the use of ELDRO® thrusters in environments of aggressive media and/or high relative humidity with the resultant formation of condensation
- » **Increased external protection:** Through special paint application, see "Mechanical version"

Brake spring (c-spring)

- » Integrated C-spring for generating the brake force. The specified brake force of the C-spring is reached at 1/3 of the nominal stroke

Versions with brake spring

Type	Brake spring force (c-spring) [N]
Eg 50/6	460
Eg 80/6	750
Eg 121/6	1,200
Eg 201/6	1,900
Eg 301/6	2,700



The logo for EMG, consisting of the letters 'EMG' in a bold, white, sans-serif font.

an **eLEXIS** company

EMG Automation GmbH
Industriestraße 1
57482 Wenden
Germany

T +49 2762 612-0
www.emg.elexis.group
info@emg-automation.com