

## eMASS®

Electro magnetic strip stabilisation

## eBACS

Edge mask control

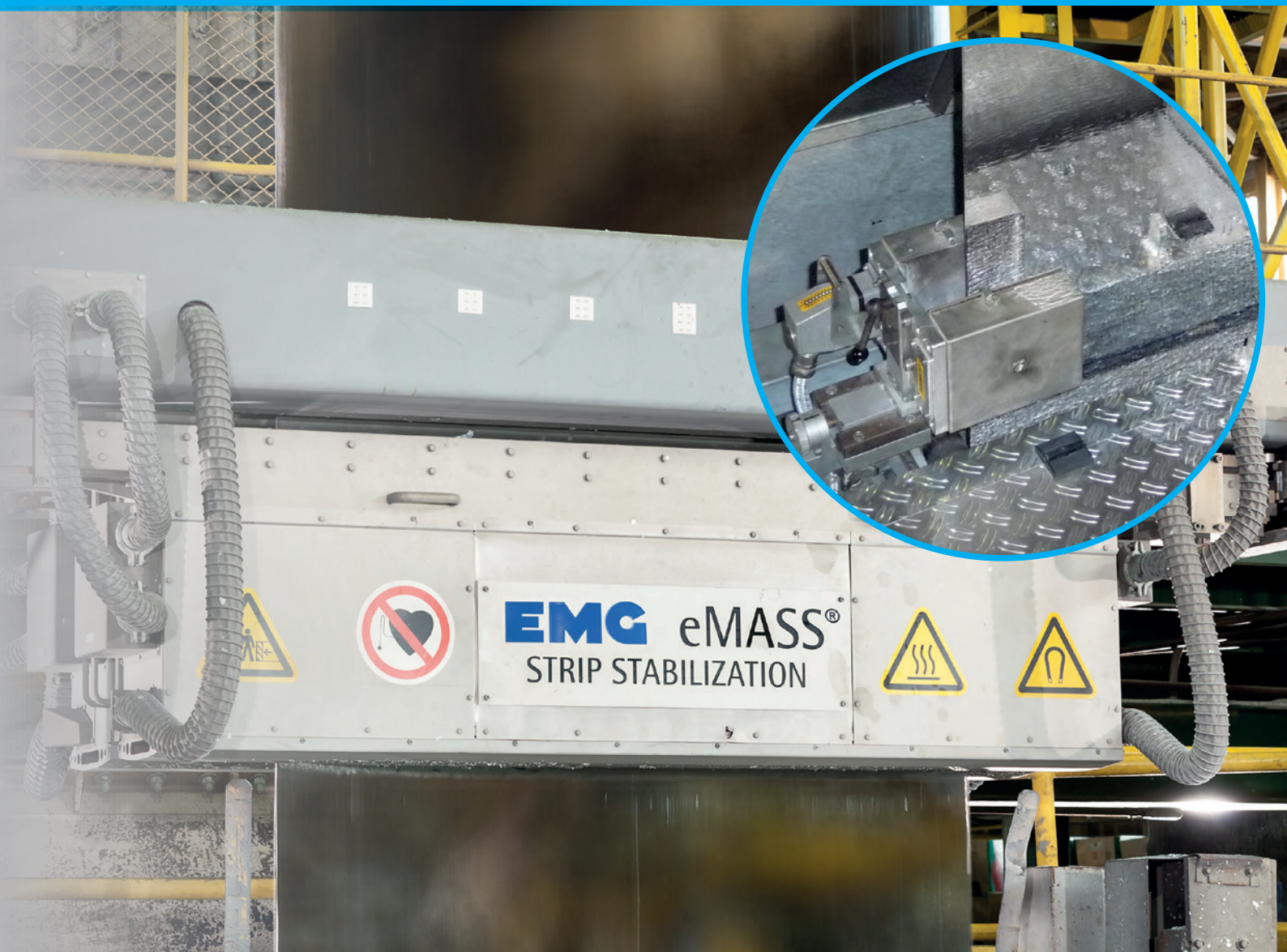

- ▶ defined and homogeneous zinc coating
- ▶ stable „pass line“ and „crossbow“ reduction
- ▶ quality optimisation and increased throughput

# Electromagnetic strip stabilisation

## EMG eMASS®

### Operating method:

Not only the guarantee of the minimum coating thickness, but also its homogeneity is an important quality feature in the production of hot-dip galvanized flat steel. A decisive factor in this regard is a stable and flat position of the strip on the „pass line“, which is the ideal centre line between the air knife lips during the controlled blowing off of excess zinc.

This is precisely what is achieved by using the EMG eMASS® system. EMG eMASS® is a turnkey system for stabilising high-speed ferromagnetic steel strip material with electromagnets. Its main applications include process and quality optimisation, as well as a reduction in the use of raw materials in hot-dip galvanising lines for various coatings (such as zinc, GALVALUME®\* and aluminium).

EMG eMASS® distinctively improves the strip shape and significantly reduces the amount of strip oscillation. This optimised blow-off process results in a significantly more homogeneous coating over the length and width of the strip. The excessive coating that was previously required to ensure a minimum layer thickness can be significantly reduced and costs lowered as a result.

The air knife process can often be further optimised, thereby enabling, for example, less frequent air knife cleaning procedures, reduced scrap, higher safety, thinner coatings and an overall lower consumption of resources.

From the more than 50 installations that have been implemented, a wide range of solutions have been developed to arrange the eMASS® system as close as possible to the „technology point“ (i.e. the air knife lip) while maintaining accessibility.

All of the project-specific boundary conditions are taken into account individually and worked out together with the customer.

### Functional principle:

The core component of EMG eMASS® is a system consisting of electromagnetic actuators and contact-free strip position sensors. Two air-cooled and movable housings are arranged on both coating sides of the strip. A row of these systems is mounted in each of these housings. Strip widths of up to 2100 mm are covered with up to 8 actuator systems per side. Depending on individual requirements, these systems can either be arranged in a stationary or individually moveable configuration. The individual movement of the actuators has maximised the coverage of all strip widths, especially the strip edges, even when subjected to lateral strip offsets.

The strip position sensors measure the deflection of the strip from its optimum position, i.e. the „pass line“, in an extremely quick and accurate manner. The measuring values are used for the controlled activation of the electromagnetic actuators. Each of these actuators pulls the strip from the corresponding side back to the pass line, or an adjustable reference position, and holds it in this position.

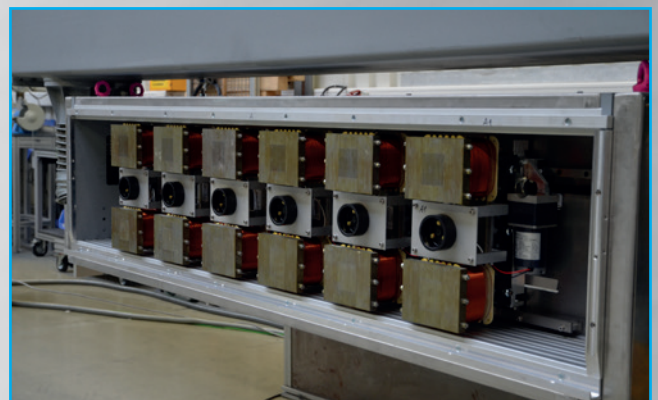

*Housing interior view (movable actuators)*

\*GALVALUME® is a registered trademark of BIEC International Inc.



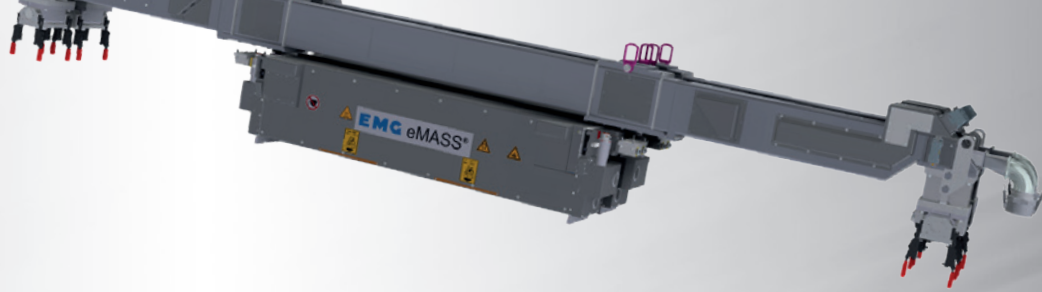

## Performance features:

- ▶ stabilisation for ferromagnetic strips
- ▶ the system can be freely scaled up to strip widths of 2100 mm, +/- 50 mm lateral strip offset
- ▶ up to 8 magnet / sensor pairs, individually movable
- ▶ low maintenance / maintenance-friendly
- ▶ extensive safety functions
- ▶ high-performance system interface (Profibus DP, Profinet)
- ▶ various software functions for system conditions
- ▶ latest EMG iCON® technology with Profinet
- ▶ optimum installation thanks to the modular design and minimised size of the actuator housings
- ▶ installation close to air knife thanks to a slim, space-optimised design
- ▶ uncomplicated handling thanks to tried and tested quick connectors (fixation, electrical system, cooling air, etc.)
- ▶ low energy consumption (< 2 kW per actuator pair)
- ▶ high cut-off frequency and extremely fast generation and reduction of force
- ▶ quick strip position control (cycle time < 1 ms)
- ▶ emergency manual adjustment in the event of a power failure

## Customer benefits

- ▶ homogeneous metal layer across the width and length of the strip
- ▶ stable „pass line“ of the strip and reduction of the „crossbow“ effect
- ▶ reducible air knife gap
- ▶ savings potential thanks to targeted and reliable production of lower coating weights
- ▶ reduced air and nitrogen consumption
- ▶ higher strip speed

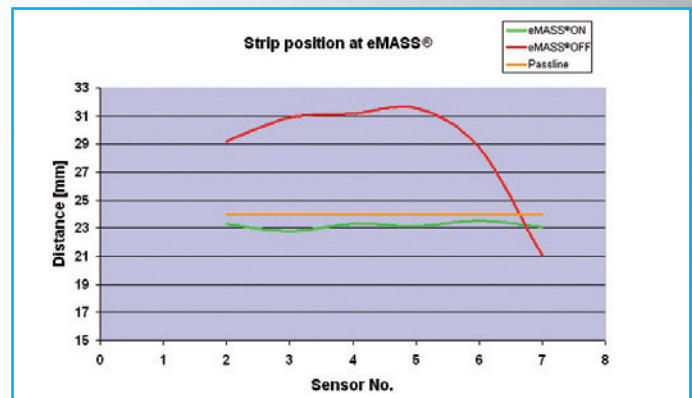

„Crossbow“ reduction  
 6 active actuators are used to pull the originally unfavourable and twisted strip position (red) far from the pass line into a position that is parallel and near to the pass line (orange), thereby straightening the bent strip shape (green).

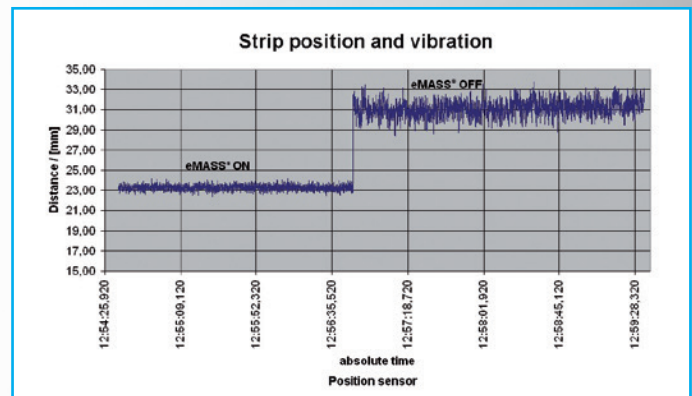

Stabilisation effect



„Our experience has shown that the EMG eMASS® system enables savings of around 50 % with regard to the average over-coating!“

Steffen Dombrowski, Product Manager for EMG eMASS®

# Electromagnetic strip stabilisation

## EMG eMASS®

### Technical data:

Area of application	all ferromagnetic steel qualities at a strip temperature of < 600 °C, typ. GI, GF, GL higher strip temperatures (e.g. for hot-dip aluminisation) are available on request austenite content ≤30 %, others on request
Weight (total) (additional air knife load)	typ. 900 kg per strip side, including brackets for inserting eMASS® into the carrier system (8 pairs of magnets at a max. strip width of 2100 mm)
Strip thickness	typ. 0.3–3 mm (others on request)
<b>Mechanics</b>	
Dimensions with carrier (W x H x D)	typ. 8500 x 840 x 950 mm for max. strip width of 2100 mm
Actuator housing	one air-cooled stainless steel housing with a heat protection shield on each strip side (temperature-resistant up to 600 °C, optional up to 800 °C)
Time for assembly or disassembly with a crane	typ. 20 min including connectors and cooling air connection
<b>Electromagnetic actuator</b>	
Force	max. 250 N at max. 20 A, typ. operating distance 35 mm and 3 mm sheet thickness; max. strip temperature 600 °C
<b>Strip position sensor</b>	
Sensor type	eddy current sensor system consisting of sensor head, sensor cable and measurement amplifier
Measuring range / resolution	10-50 mm / ≤ 0.1 mm
<b>Cooling fan</b>	
Cooling air fan with intake filter	motor rating: 2.2 kW
Dimensions (W x H x D)	625 x 700 x 1000 mm
Ambient temperature	max. 50 °C
Temperature of intake air	max. 50 °C
<b>Control cabinet components</b>	
Power input	3~, max. 18 kVA, nominal voltage, customer-specific
Power amplifier	special power amplifier with high control frequency > 100 Hz max power dissipation: 50 W
Cable set	2 sets of max. 7 cables each, partially in protective hose, max. length 50 m
Dimensions (W x H x D) / weight	typ. 3600 x 2200 x 600 mm / typ. 1000 kg

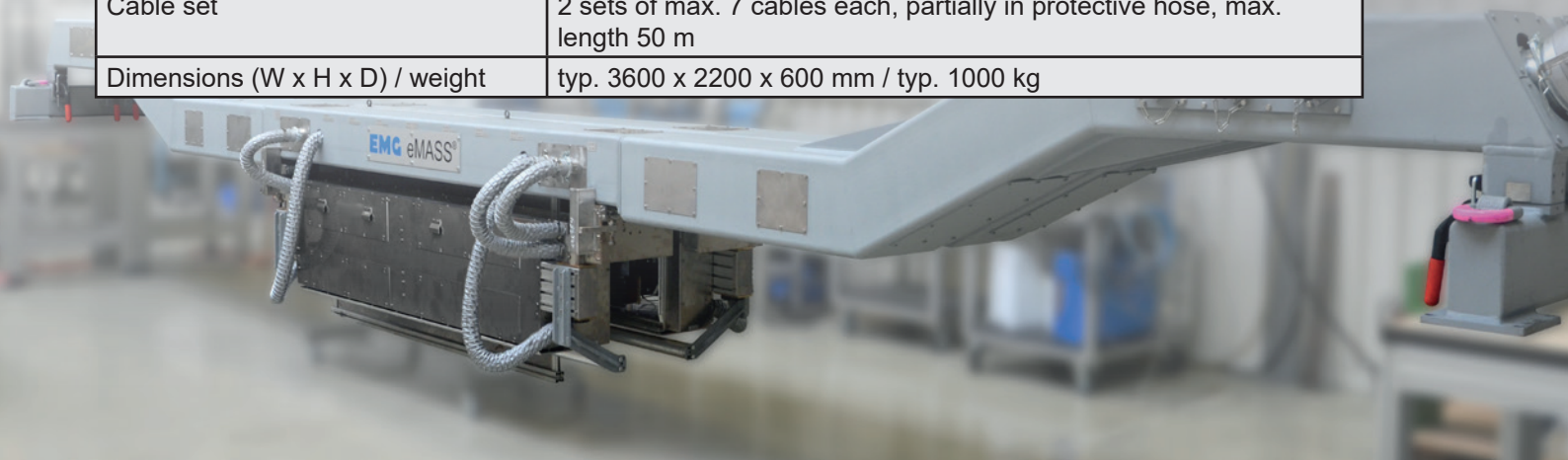

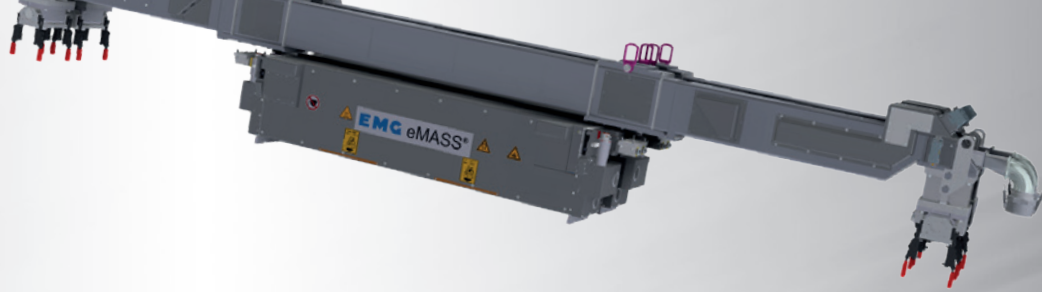

## Individual solutions for all types of air knives:

The strip vibration damping results and the increased added value that can be achieved through the use of an electromagnetic strip stabilisation system depend significantly on the optimum arrangement of the strip stabilisation system in relation to the air knife system.

**The general rule is:** the better the strip stabilisation system is integrated into the air knife arrangement and the closer the strip stabilisation system is located to the level of the air knife lips (i.e. the actual point of technology), the better the results for vibration damping and crossbow reduction. There are completely different solutions for integrating eMASS® into an existing or new system above the air knife.

The supports can, for example, be straight or cranked in order to arrange the eMASS® actuator housings as close as possible to the air knife lip in combination with the order-related design of the support structure. Here flexible adapters for individual situations exist.

Depending on the respective air knife, its vertical and horizontal travel possibilities and load capacities, the support structure can be located at the air knife, for example at the air knife height adjustment or on the plant floor. Versions with horizontal movement of the beams as well as vertical adjustment of the beams or the actuator housings under the beams are possible.

EMG also offers a partially or completely integrated solution for the strip stabilisation eMASS®, directly into the air knife of a leading air knife manufacturer, where the distance to the air knife lip can be reduced to a minimum. This is currently the best technology available in terms of maintenance and air knife lip cleaning.

As the market leader with a large number of different integration solutions worldwide, EMG will find the optimal solution for you.

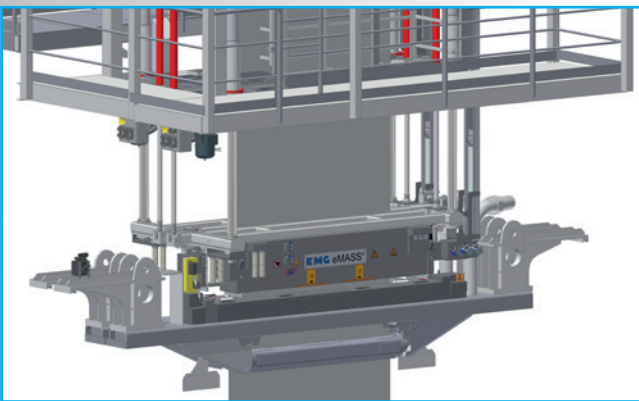

*Variable height installation on mobile tower*

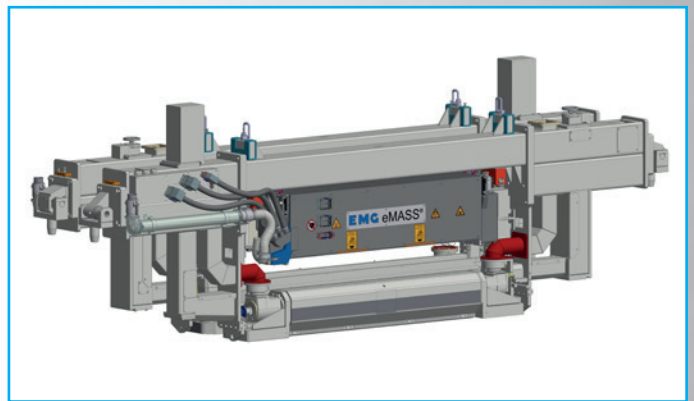

*Integrated solution with minimum distance to air knife lip*

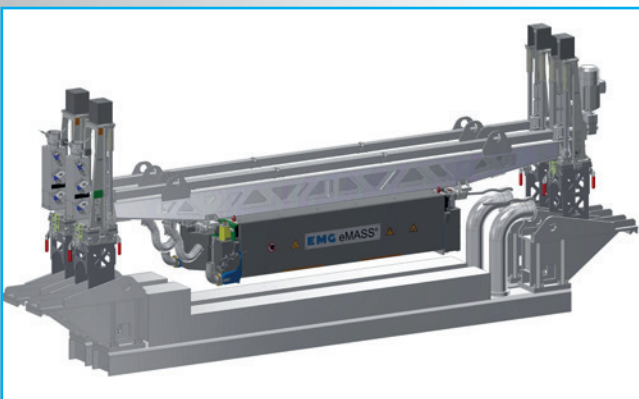

*Very light solution due to special carrier construction*

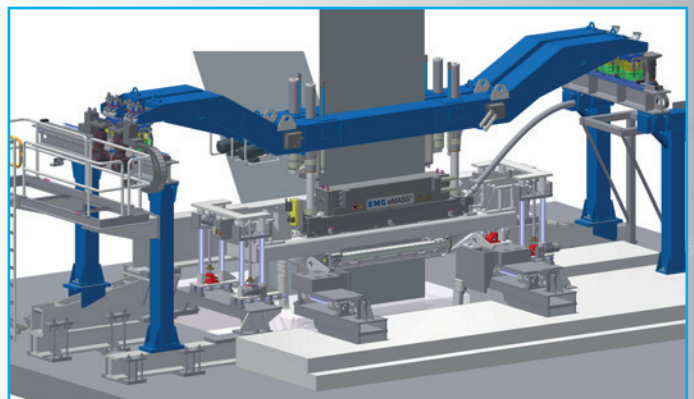

*Height-adjustable actuator box and laterally-adjustable supporting construction*



# Edge mask control

## EMG eBACS

### Application:

In hot-dip coating lines, the air outlet gap of the blow-off nozzles (air knives) is at least as wide as the widest running strip. So-called “edge masks” or “baffle blades” are a feature of the air knives that widen narrower strip material to avoid air turbulence occurring at the edges. This can prevent impairment of the zinc layer at the strip edges (“growths”), while also significantly reducing the level of noise generated by the flowing air.

The edge masks are normally controlled pneumatically and pressed against the strip edges by contact rolls, which is particularly disadvantageous for thin strip material. Deposits of hot coating material such as zinc, GALVALUME® and aluminium, however, also result in problems.

\*GALVALUME® is a registered trademark of BIEC International Inc.

The EMG eBACS contact-free inductive measuring system with the new generation ESI1 edge sensors replaces these contact rolls. The use of high-precision linear drives also allows the edge masks to be positioned in a very flexible manner compared to pneumatic operation with only two positions (open/closed).

The edge mask distance can be adjusted remotely. The gap width for the critical weld seam pass, which must be signalled by the system control unit in a timely and sufficiently long manner, can be minimised and the edge masks follow the strip edges precisely and without contact.



*Complete system for edge mask control mounted on the air knife device (Focus: eBACS sensor)*

### Functional principle:

The ESI1 sensor consists of a transmitter coil and a receiver coil, which are installed opposite each other in a protective housing with connector plugs and a high-temperature-proof special cable. A strip passing through the system alters the field between the coils.

The SMI evaluation electronics processes the signals from one or two sensors.

The EMG iCON® controller now processes the signals again for a third-party drive control system, or it regulates the correcting variable for the eBACS drives in order to allow the edge masks of the strip edge to follow at a specified and adjustable distance.

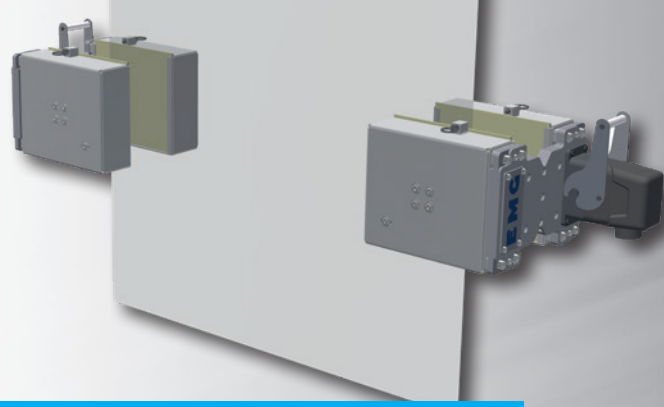

## Individual components for OEMs:

EMG supplies components for the various providers of air knives with edge mask devices.

In the simplest case, these are just the strip edge sensors with special cables and signal amplifiers, however, it can also include actuators and position measurement systems.

EMG compiles individual solutions together with the air knife manufacturers and provides support for structural and electrical integration.

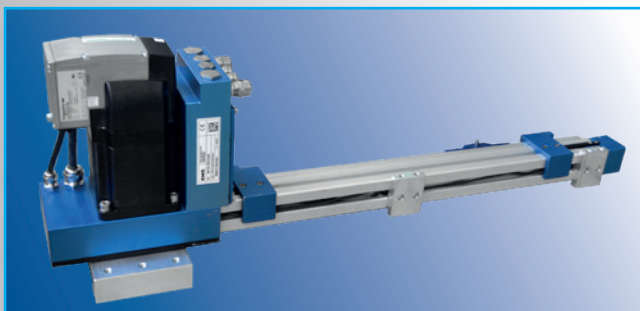

*Linear actuator ESA 10-.../L*

## Customer benefits:

- ▶ contact free and high-precision strip edge detection
- ▶ elimination of mechanical contact rolls with all of their disadvantages
- ▶ no deformation of the strip edge
- ▶ a more homogeneous zinc coating of the strip edge
- ▶ remote adjustment of the mask distance
- ▶ maintenance-free strip edge sensors and low maintenance requirements for the drive technology
- ▶ compact and air knife-specific integration
- ▶ derivable strip position and strip width measurement

## Installation as a platform system:

EMG's eBACS system is frequently seen as a useful addition to the EMG eMASS® system, however, it is also used as a separate solution in its own right.

EMG supplies end users with tailor-made platform systems for retrofitting existing air knives and their edge mask devices. The EMG components (such as drives, drag chains, position measurement systems, sensor amplifiers, etc.) are preassembled and wired in a housing.

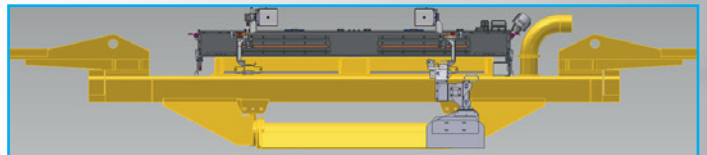

This housing is then mounted above the existing structure by means of simple weld-on feet. In most cases the system is connected to existing linear units, but it is also possible to insert new linear units as well. The strip edge sensors are attached to the upper end of the edge masks and replace the contact rolls.



---

## **EMG Automation GmbH**

Industriestraße 1  
57482 Wenden  
Germany

Phone: +49 2762 612-0

Fax: +49 2762 612-384

[automation@emg-automation.com](mailto:automation@emg-automation.com)

[www.emg-automation.com](http://www.emg-automation.com)

**eLEXIS Group**