



EMG Automation GmbH

EMG hotCAM

Optical position measurement at hot strip



Hot rolling process

The hot rolling process is typically a combination of a reversing mill (roughing mill) and a multi-stand hot rolling mill (finishing line).

For the process reliability in a hot rolling mill it is extremely important to keep a defined position of the strip between the hot rolling stands. The continuous measurement of the strip position allows an optimised adjustment of the rolling force and gap.

In reversing mills this can lead to a reduction of the camber of the strip and thus prevents collisions of the strip with the mechanical strip guiding rail.

The continuous control of the centre position in a hot rolling mill also reduces cobbles (outbreaks) of the strip, which lead to serious damages and production stops.

With the measured parameters transmitted to the level-2-system, the line operator is able to realise a closed loop system (sensor and mill) for camber reduction and optimized strip positioning in the hot rolling mill.

The solution EMG hotCAM for position measurement helps you to increase your product quality and to avoid damage to your line!

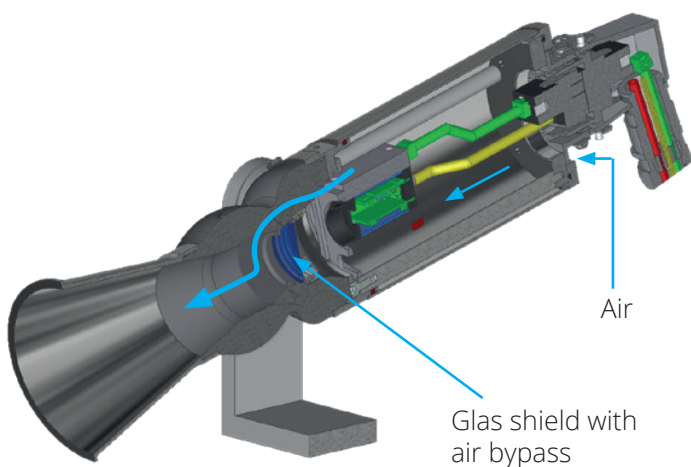

Housing with air flushing / cooling

Ideal strip position

EMG solution

During hot rolling processes in a multi-stand rolling mill, the position of the moving hot strip changes between the rolling stands. By detecting this position, the optimised adjustment of the rolling force and gap is possible, to keep the strip in the middle of the line.

By knowing the strip position at each rolling step, the on-line control of the slab/strip movement becomes much more effective. Furthermore, it helps to avoid critical movements of the strip, leading in the worst case to cobbles of the hot strip between the rolling stands. EMG hotCAM provides not only the basic data to prevent collision of the strip with the mechanical strip guiding of the line and to improve the coil quality, but moreover it helps to protect the mill against disaster events.

With special mathematical corrections and algorithms for image processing the optical position measurement system EMG hotCAM compensates errors of the optic. After this correction and considering the height position of the looper as well as the size of the rolling gap (actual values for each) EMG hotCAM calculates the strip position between the rolling stands exactly.

The strip edge detection is largely independent of rising water steam. Due to a special design of an air flushing the pollution of the optic is prevented.

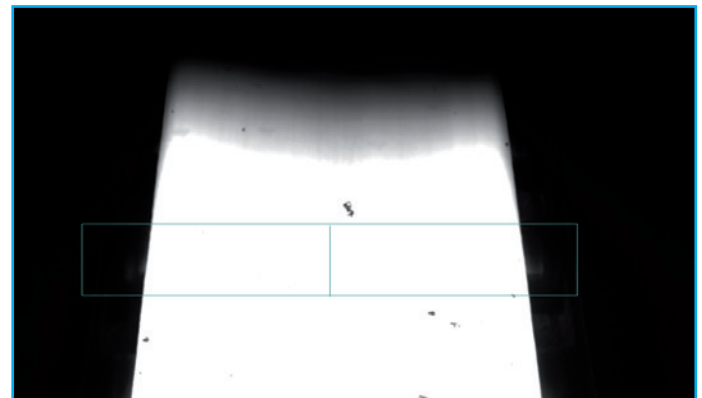

Camera view and region of interest of EMG hotCAM in the hot rolling mill

Technical data

Environmental temperature	up to 100 °C (depends on the cooling air temperature)
Minimum strip temperature	820 °C (lower temperatures on request)
Cooling / Air flushing	compressed air (approx. 500 l/min; > 5 bar)
Accuracy strip width measurement	up to +/- 1.5 mm
Accuracy position measurement	up to +/- 1.5 mm
Interface to PLC	Profibus/Ethernet
Measuring rate	50 Hz - 60 Hz
Scalability (no. of measuring sets)	1-n
Measuring distance	approx. 4-8 m (mounted on top of the roll stand)

Higher operational safety & Improved strip quality

Customer benefits

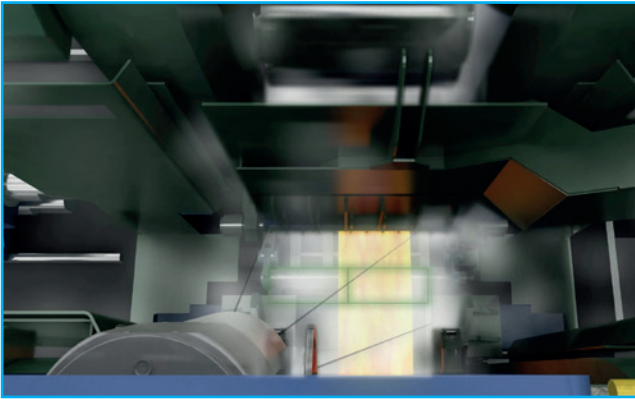

View area of EMG hotCAM optic

- Easy to integrate system
- Little maintenance required on the camera
- Improved process stability and safety
- Targeted error analysis through extended process data (position value between the stands)
- Evaluation of individual images (PDF report of each strip with strip end images)
- Better manual control by the operator through direct feedback
- Integrated strip guiding

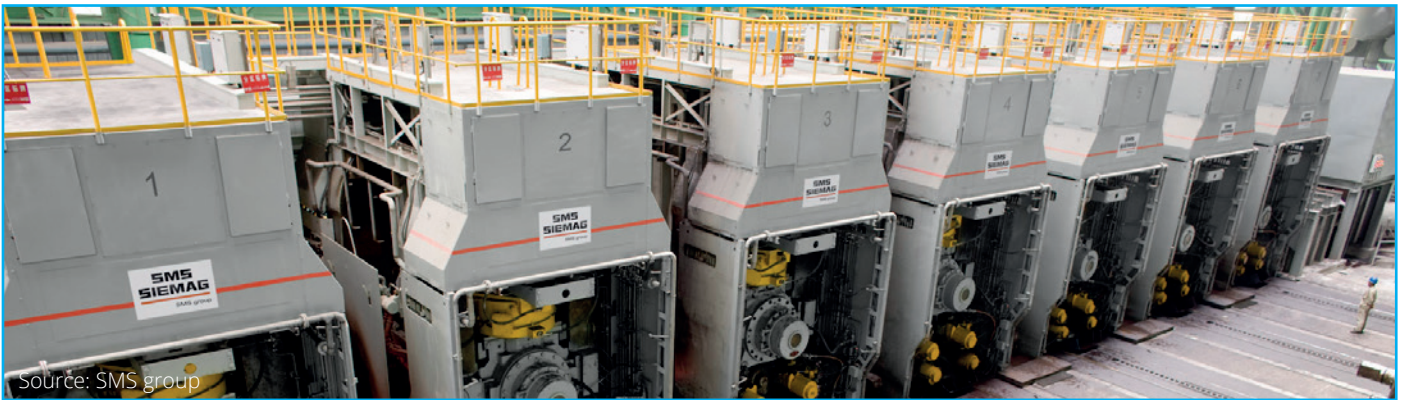

Rolling stands in a finishing line

Performance features

- CMOS area scan camera takes near infrared (NIR) pictures of the hot strip; minimum strip temperature 820 °C
- The strip edges are detected exactly
- Mathematical algorithms compensate errors (such as vapor, dust and steam)
- The program calculates the position and the width of the strip accurately
- The measuring data is transferred to the line PLC
- The system is scalable for several rolling stands
- Temperature monitoring
- Corrosion-resistant housing
- Optic shutter in case of air pressure drop (optional)
- Air monitoring (optional)
- Air preparation acc. to ISO 8573-1:2010 (optional)

Closed control loop with X-Pact® Strip Steering Control

Using the EMG hotCAM centre position, a closed control loop can be realised in a finishing line.

EMG draws on the many years of experience of the SMS Group, which has developed the SMS X-Pact®, a product that demonstrably stabilises the rolling process. With this combination of position measurement on the hot strip EMG hotCAM and the closed control loop, EMG offers comprehensive process optimisation in the hot strip area.



Customer benefits

- Sheared strip ends are reduced
- Fewer unscheduled roll changes necessary
- Improvement of process stability
- Stabilisation of the strip position
- Improvement of the strip geometry
- Reduced operator intervention in the line
- TOM (Tail Out Monitor) - Improved operator support



EMG Automation GmbH

Industriestraße 1
57482 Wenden
Germany

Phone: +49 2762 612-0

automation@emg-automation.com
www.emg-automation.com

member of **eLEXIS**